

2.3

Acceleration



Question: How is the speed of the car changing?

In this Investigation, you will:

1. Determine the rate of acceleration of the car on the ramp through a calculation.
2. Determine the rate of acceleration of the car on the ramp using a graph.

For this Investigation, you will examine the data you collected from Investigation 2.2 with the car and ramp. Using your data, you will determine the rate of acceleration of the car in two ways: through calculation using an equation, and with a graph by taking the slope of the line.

Before beginning the Investigation, define the term “acceleration” in your own words. It may help you to think about flying in an airplane. When a plane is accelerating, you feel its motion. For example, you feel the motion of the plane when it is taking off, but not much when you are flying at altitude.

1 Measuring acceleration

Acceleration is the rate at which the speed changes. For the car on the ramp, the change in speed is the difference between the speed at photogate B and the speed at A. The change in time is the time from A to B. You can calculate acceleration by dividing the change in speed by the change in time.

$$\text{acceleration} = \frac{\text{speed at B} - \text{speed at A}}{\text{time from A to B}}$$

1. Put photogate A about 30 centimeters from the top of the ramp and photogate B another 20-30 centimeters farther down. Leave both photogates in the same position for the rest of Trial 1.
2. Set the ramp at the same angle as you used for the last Investigation so you can compare the data.
3. For Trial 1: With the timer in interval mode, roll the car down the ramp and record the three times (t_A , t_B , and t_{AB}) in the table.
4. Calculate the speeds at points A and B, and the acceleration of the car from the acceleration formula above.
5. For Trial 2: Move the photogates to a new position and repeat the procedure to measure the acceleration.

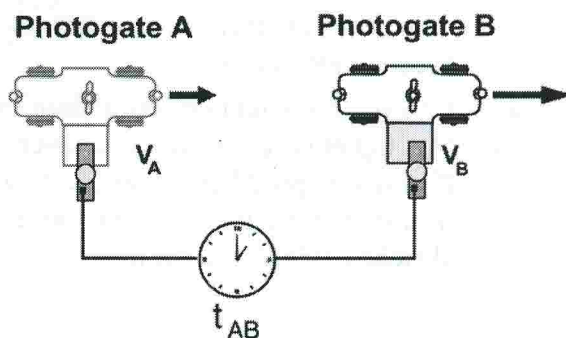
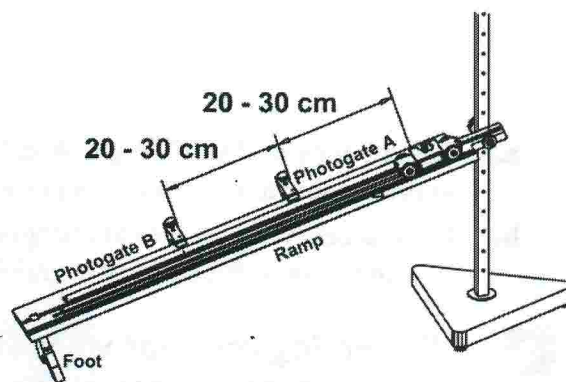

	Trial 1	Trial 2
Time A		
Time B		
Time A to B		
Speed at A		
Speed at B		
Acceleration		

2 Graphing speed vs. time

- Make a speed vs. time graph. Use your data from *Investigation 2.2 Position and Time (Part 3)*. Plot the speed at photogate B on the y-axis. Plot the time from A to B on the x-axis.
- Is your graph a straight line or a curve?
- The place on the speed vs. time graph where the line crosses the y-axis is called the *y-intercept*. On the speed vs. time graph for the car and ramp, the *y-intercept* represents something about the car. What is the *y-intercept* of your speed vs. time graph? (Hint: The *y-axis* is speed.)
- Does the car accelerate as it rolls down the ramp? Justify your answer. Remember that acceleration is defined as a change in speed over time.

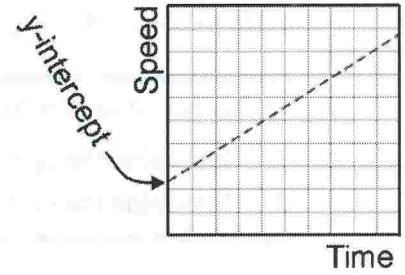

3 $\frac{a}{b}$ Calculating acceleration from the slope of the line

In a speed vs. time graph, you are showing the change in speed over time. The slope of the speed vs. time graph is equal to the *acceleration* of the car.

Acceleration from the slope of the speed vs. time graph

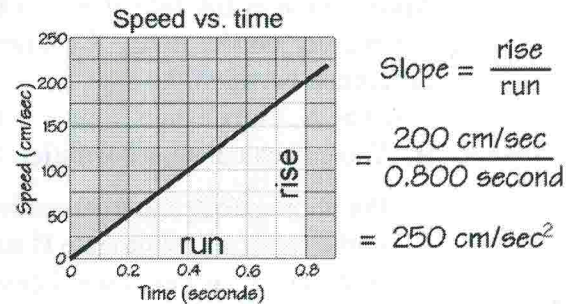

- Using your speed vs. time graph, calculate the acceleration of the car from the slope of the line. Refer to the graphic to the right for an example of the calculation. Show all of your work.
- Is the acceleration of the car changing as it moves down the ramp? Explain your answer using what you know about the slope of a straight line.

4 Reflecting on what we learned

- How does the acceleration you measured compare with the acceleration you calculated from the graph of speed vs. time? If there are differences, try to think where they might have come from.
- Give the car a gentle push up the ramp from the bottom. The car will go up, slow down, and come down again. Is there a place in the motion where the speed of the car is zero? Is there a place where the acceleration is zero?
- Can you think up two configurations of ramps and cars that show the following properties:
 - Higher speed but lower acceleration.
 - Lower speed but higher acceleration.
 You should discuss this with your group or the class. You can also test out your ideas, or draw them in sketches. (Hint: The car may not always be in the same place!)